



Tap Holder

SYNCHROMASTER

Vol.2



Polygon Taper Shank
5 new sizes added

KEY FEATURES: SYNCHROMASTER

1 Enables accurate depth control
Achieves stable performance even with difficult small chamfer

3 Prevents sudden breakage

2 Improves thread quality

4 Prolongs tool life

5 The combination of SynchroMaster and synchronous feed machines brings out the best of your A-TAP tools



SYNCHROMASTER TAP HOLDER

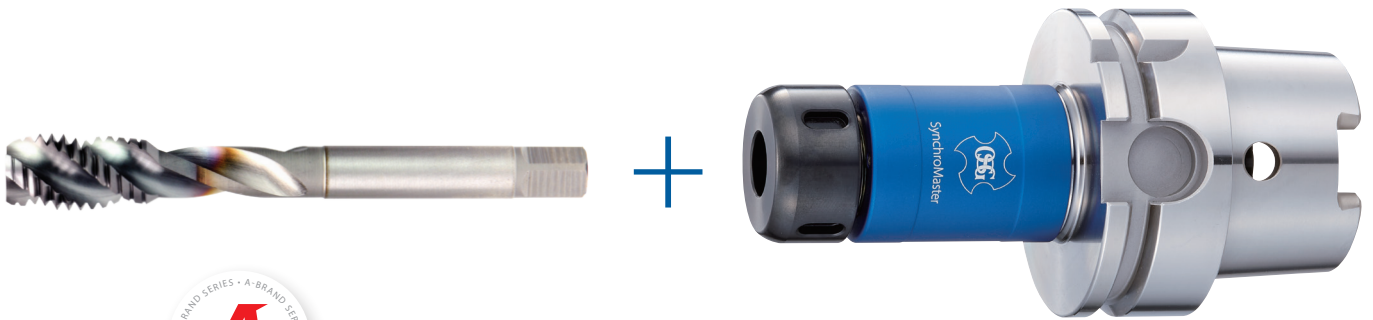

A-TAP & SYNCHROMASTER THE BEST SOLUTION

SynchroMaster reduces axial and radial forces to enable the A-Tap series to reach its maximum potential !

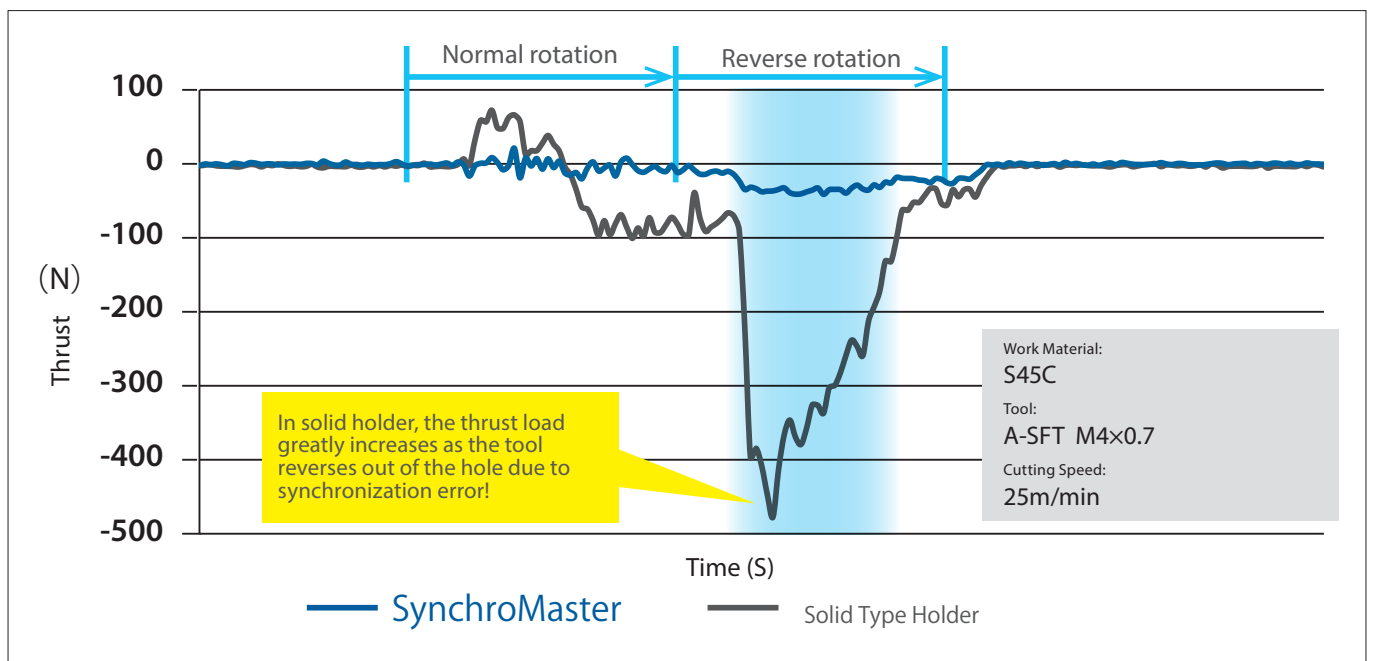

Machine	Holder	Tap (example)	Recommendation
Machine with synchronous feed mechanism	SynchroMaster	A-TAP (A-SFT, A-POT, S-XPF)	●
		General purpose tap (EX-SFT, TIN-POT)	○

Synchro Tap is recommended to be used in combination with a solid holder and machine with synchronous feed mechanism

●: Best ○: Good



SYNCHROMASTER TAP HOLDER

The secret lies in its integrated single unit construction!

- Original metal flexure mechanism enables long tool life
- Ultra-small float mechanism ensures consistent tapping depth



- Disadvantages of General micro float holder
- Float mechanism that allows the 2-piece body construction with resin or rubber type damper to move in the thrust direction
 - Early degradation of the damper mechanism
 - Requires maintenance

Long tool life

Stable performance even with difficult short chamfer

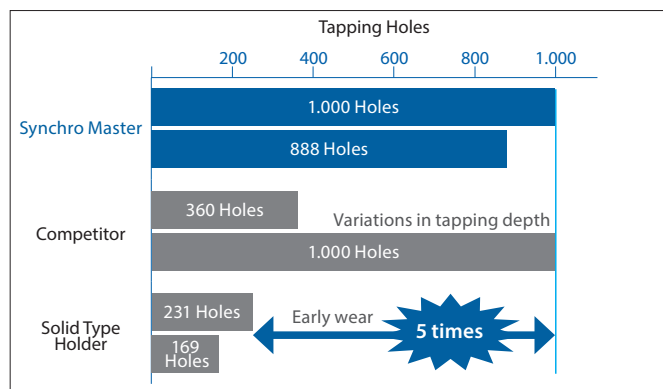

Work Material: S45C Tool: A-SFT M4x0.7 1P Cutting Speed: 10m/min

Durability of forming taps can also be improved

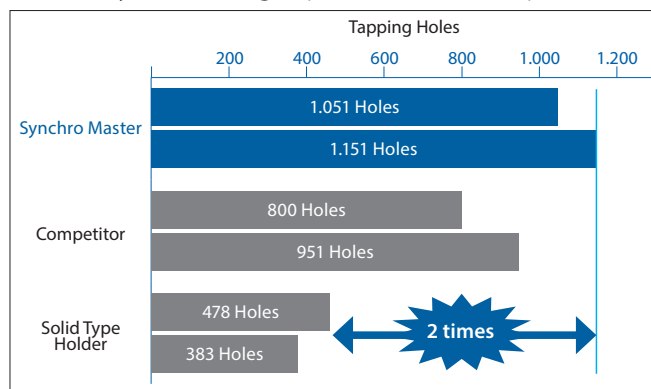

Work Material: SCM440 (30HRC) Tool: S-XPf M10x1.5 2P Cutting Speed: 15m/min

Suppresses variations in tapping depth

Achieves high precision tapping depth comparable to solid type holder

Holder	Tap (example)
SynchroMaster	0.10 mm
Competitor	0.20 mm
Solid Type Holder	0.07 mm

Work Material: S45C Tool: S-XPf M10x1,5 2P Cutting Speed: 22m/min

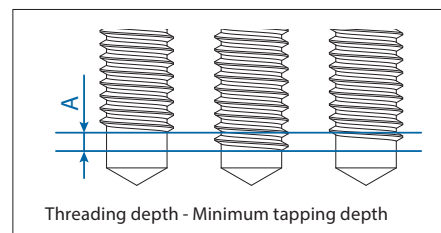

SynchroMaster (Holder+Nut)



Collet (Sold separately)



Spanner (Sold separately)

SYNCHROMASTER NEW SIZES

Threading | Holder | SynchroMaster



Polygon Taper Shank Holder

- Tap holder synchronized
- Improve the tool life
- For tapping sizes from M3 to M24
- HSK & BT type for ER16, ST & Polygon Taper Shank Type for ER16 & ER32 collet

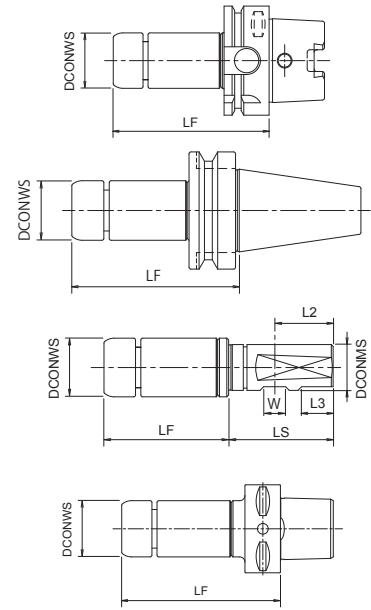

EDP	Designation	LF	LS	DCONWS	DCONMS	L2	L3
79912	HSK40A-SMH16-85	85	-	32	-	-	-
79913	HSK63A-SMH16-90	90	-	32	-	-	-
79910	BT30-SMH16-90	90	-	32	-	-	-
79911	BT40-SMH16-90	90	-	32	-	-	-
79924	ST20D-SMH16-68	68	51	32	20	25	-
79925	ST25D-SMH16-68	68	57	32	25	32	17
48329004	ST20D-SMH32-87	87	51	50	20	25	-
48329002	ST25D-SMH32-87	87	57	50	25	32	17
79994	C4-SMH16-90A	90	-	32	-	-	-
79995	C5-SMH16-90A	90	-	32	-	-	-
79996	C6-SMH16-90A	90	-	32	-	-	-
79997	C5-SMH32-120A	120	-	50	-	-	-
79998	C6-SMH32-120A	120	-	50	-	-	-

Accessories and spare parts

Applicable	EDP	Designation	Specification
SMH16	79923	FKT-32L	Wrench
SMH16	79922	ERP-16T	Cap Nut
SMH32	79993	FKT-50L	Wrench
SMH32	79992	ERP-32T	Cap Nut

SYNCHROMASTER Collet

Threading | Holder | SynchroMaster

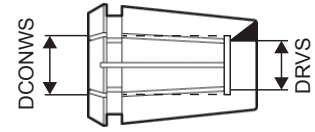

EDP	Designation	DCONWS	DRVS	DIN 371	DIN 376
79949	ER16GH3,52,7	3,5	2,7	M3	M5
79951	ER16GH4,53,4	4,5	3,4	M4	M6
79953	ER16GH64,9	6	4,9	M5 M6	M8
79919	ER16GH75,5	7	5,5	M7	M10
79955	ER16GH86,3	8	6,3	M8	M11
79956	ER16GH97,1	9	7,1	M9	M12
79970	ER32GH-7x5,5	7	5,5	M7	M10
48329007	ER32GH-8x6,3	8	6,3	M8	M11
48329008	ER32GH-9x7,1	9	7,1	M9	M12
79973	ER32GH-10x8	10	8	M10	-
79975	ER32GH-11x9	11	9	-	M14
79976	ER32GH-12x9	12	9	-	M16
79978	ER32GH-14x11,2	14	11,2	-	M18
79980	ER32GH-16x12	16	12	-	M20
48329014	ER32GH-18x14,5	18	14,5	-	M22 M24



www.osgeurope.com





shaping your dreams

OSG EUROPE LOGISTICS

Avenue Lavoisier 1
B-1300 Z.I. Wavre - Nord - Belgium
Tel: +32 10 23 05 07
info@osgeurope.com

OSG POLAND Sp. z o.o.

Spółdzielcza 57
05-074 Halinów - Poland
Tel: +22 760 82 71
osg@osg-poland.com

OSG ROMANIA SRL

25C, Bucuresti-Magurele Street (Sector 5)
051431 Bucuresti - România
Tel: +40 21 322 07 47
info@osgromania.ro

OSG BELUX

Avenue Lavoisier 1
B-1300 Z.I. Wavre - Nord - Belgium
Tel: +32 10 23 05 11
info@osg-belgium.com

OSG GERMANY

Karl-Ehmann-Str. 25
D - 73037 Göppingen - Germany
Tel: +49 7161 6064 - 0
Fax: +49 7161 6064 - 444
info@osg-germany.de

AUSTRIA

Branch office of OSG GERMANY
Messestraße 11
A-6850 Dornbirn
Tel: +49 7161 6064-0
info@osg-germany.de

OSG FRANCE

Parc Icade, Paris Nord 2
Immeuble "Le Rimbaud"
22 Avenue des Nations
CS66191 - 93420 Villepinte - France
Tel: +33 1 49 90 10 10
sales@osg-france.com

OSG SCANDINAVIA

(For Scandinavian countries)
Langebjergvaenget 16
4000 Roskilde - Denmark
Tel: +45 46 75 65 55
osg@osg-scandinavia.com

OSG ITALIA

Via Ferrero, 65 A/B3
I - 10098 Rivoli - Italy
Tel: +39 0117705211
info@osg-italia.it

OSG NETHERLANDS

Bedrijfsweg 5 - 3481 MG Harmelen
Tel: +31 348 44 2764
info@osg-nl.com

SWEDEN

Branch office of OSG SCANDINAVIA
Singelgatan 7
212 28 Malmö - Sweden
Tel: +46 40 41 22 55
osg@osg-scandinavia.com

Vischer & Bolli AG

Machining and Workholding
Im Schossacher 17
CH-8600 Dübendorf
T +41 44 802 15 15
info@vb-tools.com

OSG UK

Kelsey Close, Attleborough Fields Ind Est,
CV11 6RS, Nuneaton, United Kingdom.
Tel: +44 1827 720 013
uk_sales@osg-uk.com

OSG IBERICA

Bekolarra 4
E - 01010 Vitoria-Gasteiz - Spain
Tel: +34 945 242 400
osg.iberica@osg-ib.com

CZECH, SLOVAKIA, HUNGARY

OSG Europe Logistics S.A.
Slovakia organizacna zlozka
Racianská 22/A, SK-83102 Bratislava
Slovakia
Tel. +421 24 32 91 295
Orders-osgsvk@osgeurope.com

OSG TURKEY

Rami Kışla Cad.No:56 Eyüp
Istanbul 34056 - Turkey
Tel+90 212 565 24 00
Fax: +90 212 565 44 00
info@osg-turkey.com

OSG EUROPE LOGISTICS S.A.

06/2024- All rights reserved. © OSG Europe 2024.

The contents of this catalogue are provided to you for viewing only. They are not intended for reproduction either in part or in whole in this or other medium. They cannot be copied, used to create derivation work or used for any reason, by means without the express, written permission of the copyright owner. If prices are stated, they are netto unit-prices and any eventual tax(es) have to be added. The company is not responsible for any printing error in technical, price and/or any other data.

Tool specifications subject to change without notice.

www.osgeurope.com